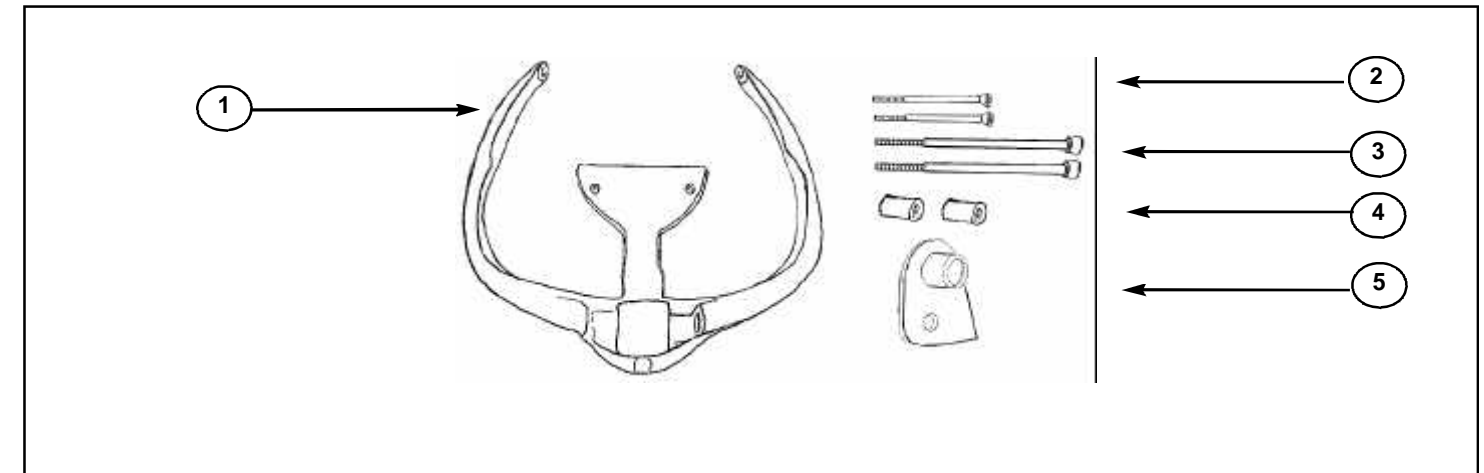

⚠ WARNING

If the addition of an accessory(ies) adversely affects your motorcycle's stability, immediately remove the accessory(ies). Do not ride a motorcycle that exhibits unsafe handling traits. Have experienced service personnel correct any problem before riding with the accessory(ies) installed. For further questions concerning handling problems associated with an accessory(ies), contact your dealer, motorcycle manufacturer, or accessory manufacturer.

**NOTE**

This accessory is designed to work with the BMW large passenger seat and pan. The seat must be installed prior to or at the time of the hand rail.

PARTS LIST

<u>Ref.</u>	<u>Description</u>	<u>Qty.</u>
1	Hand Rail	1
2	Screw, M6 x 50 Flat Head	2
3	Screw, M6 x 90 Socket Head	2
4	Spacer, 19mm OD x 20mm Long	2
5	Handrail Cam Insert	1

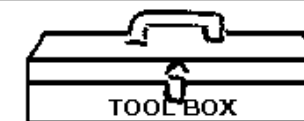
TOOLS REQUIRED

<u>Ref.</u>	<u>Description</u>
1	Hex Key Wrench, 4mm
2	Drift Punch
3	Mallet
4	Hex Key Wrench, 6mm
5	Socket, 10mm
6	Socket, 13mm
7	Socket Wrench
8	Hex Key Wrench, 5mm
9	Dremel Moto-tool (or equivalent) with 1" diameter cut-off wheel

PREPARATION

1. Remove Parts

Place the motorcycle securely on its side stand or a work stand.

Remove the original passenger hand rail (Hex Key Wrench, 4mm). Set it aside, the hand rail and its screws will not be reused.

Remove the acorn nut and flat washer from the seat backrest pivot bolt (socket, 13mm and hex key 6mm). Figure 1.

Remove the pivot bolt by gently tapping with drift punch. Figure 2.

Remove the seat pad by pulling the seat pad adjustment knob out as far as possible and lifting the seat pad out of its holder.

NOTE

The seat pad and pivot bolt will be re-used later. The acorn nut and washer will not be reused.

Remove the 6mm nuts and washers located inside the fender, that retain the rubber covers to the fender brace (socket, 10mm). Figure 3.

NOTE

The fender will be loose when both rubber covers are removed. Retain the nuts for further use. The rubber covers will not be reused.

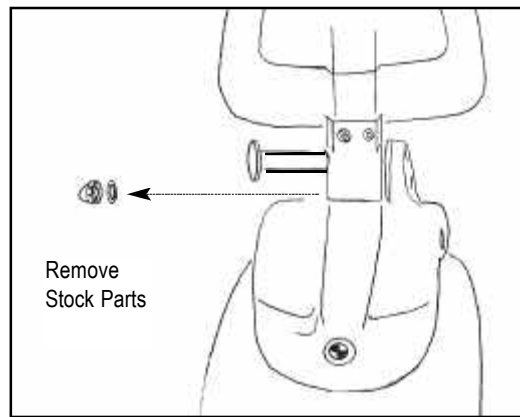

Figure 1.

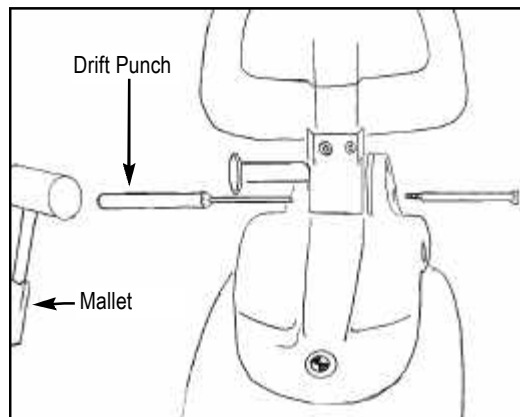

Figure 2.

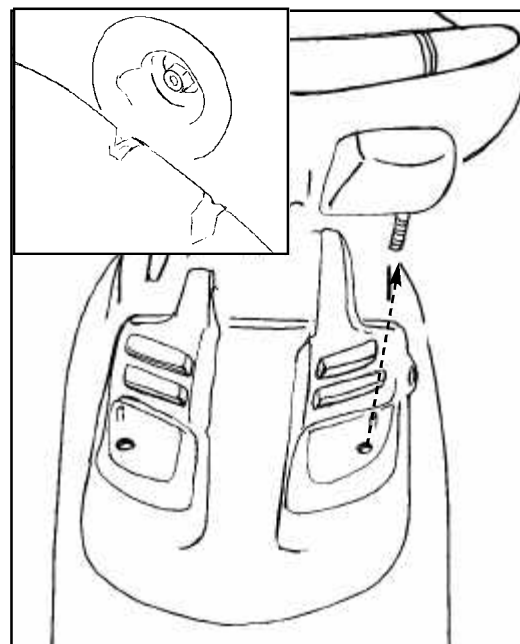

Figure 3.

INSTALLATION

1. Position and align hand rail over fender cover.

Position holes of hand rail with fender cover. Fix in place with the M6 x 50 flat head screws (2) through the hand rail, the fender cover, the chassis, and the fender. Fasten from inside the fender, with the 6 mm nuts and washers removed in preparation step reference figure 3. **Do not tighten.** Figure 4.

Fix hand rail in place with the M6 x 90 socket head screws (3) through the forward mounts of the hand rail, the fender cover, and into the frame. **Do not tighten.** Figure 5.

Tighten the M6 x 50 flat head screws to 13 Nm (10 ft/lbs).

Remove the M6 x 90 Socket Head Screws.

2. Mounting hand rail and large passenger seat

Assemble the large passenger seat and position the seat as directed in its installation instructions. Start the rear screws for the accessory seat.

Place the spacers (4) between the front mounts of the hand rail and the accessory seat front bushings then start the M6 x 90 socket head screws (3). Figure 6.

NOTE

If installing National Cycle N1101 saddlebags or BMW saddlebags, the saddlebag mounting frame will replace the spacers.

Tighten the rear screws for the accessory seat as directed.

3. Mounting seat pan and pad

For clearance of the grab rail center brace, carefully cut out the window at the rear of the large passenger seat pan (dremel). Follow the "witness line" on the inside surface of the trim panel. Figure 7.

NOTE

A fine flat file can be used to smooth the cut-line if needed.

Install the trim panel as directed in its installation instruction.

Install the cam insert (5) to hand rail. Figure 8.

Attach the seat pad to the hand rail in reverse sequence from its removal, using the pivot bolt removed in preparation step reference figure 2. Tighten to 5.5 Nm (4 ft/lbs).

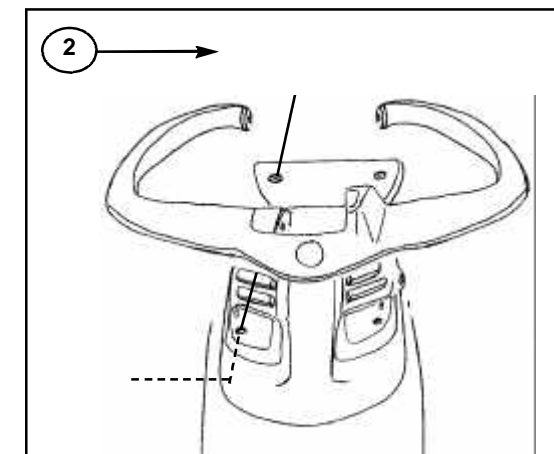

Figure 4.

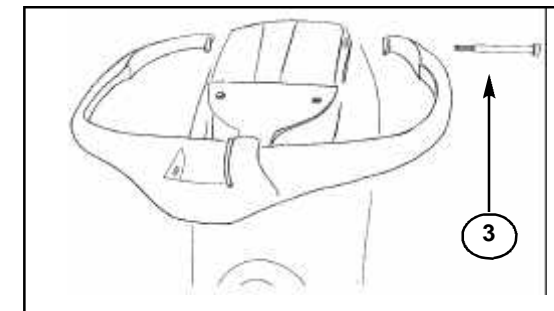

Figure 5.

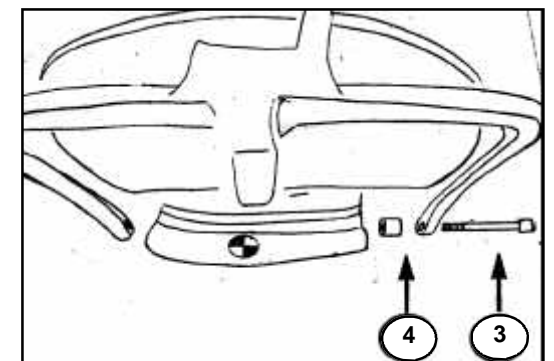

Figure 6.

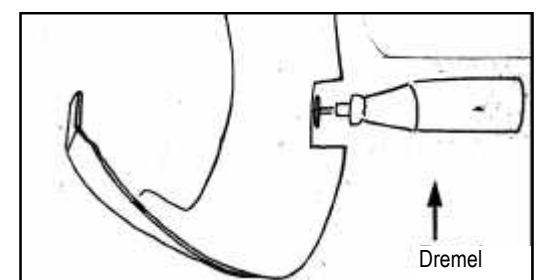

Figure 7.

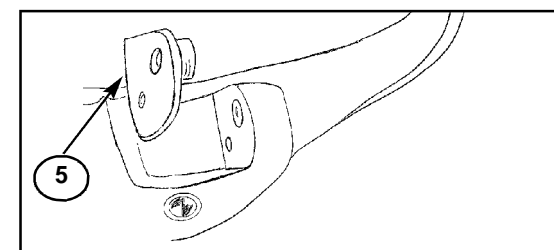

Figure 8.