

4mm Hex Wrench
Loctite® threadlocker (optional)

PARTS LIST for Helmet Lock Z5505

Index	Part No.	Description	Qty.
1	70-700402-000	License Bracket	1
2	80-861010-000	Lock Set (2 locks)	1
3	51-516313-000	Screw, M6 x 12	4

NOTE U.S.A. Customers: Wisconsin State Department of Transportation does not comply with SAE license plate standards. Only the top two holes of Wisconsin plates align with the Z5505 Helmet Lock backing plate.
NOTE: Right and Left side of Motorcycle is determined while sitting on the bike.

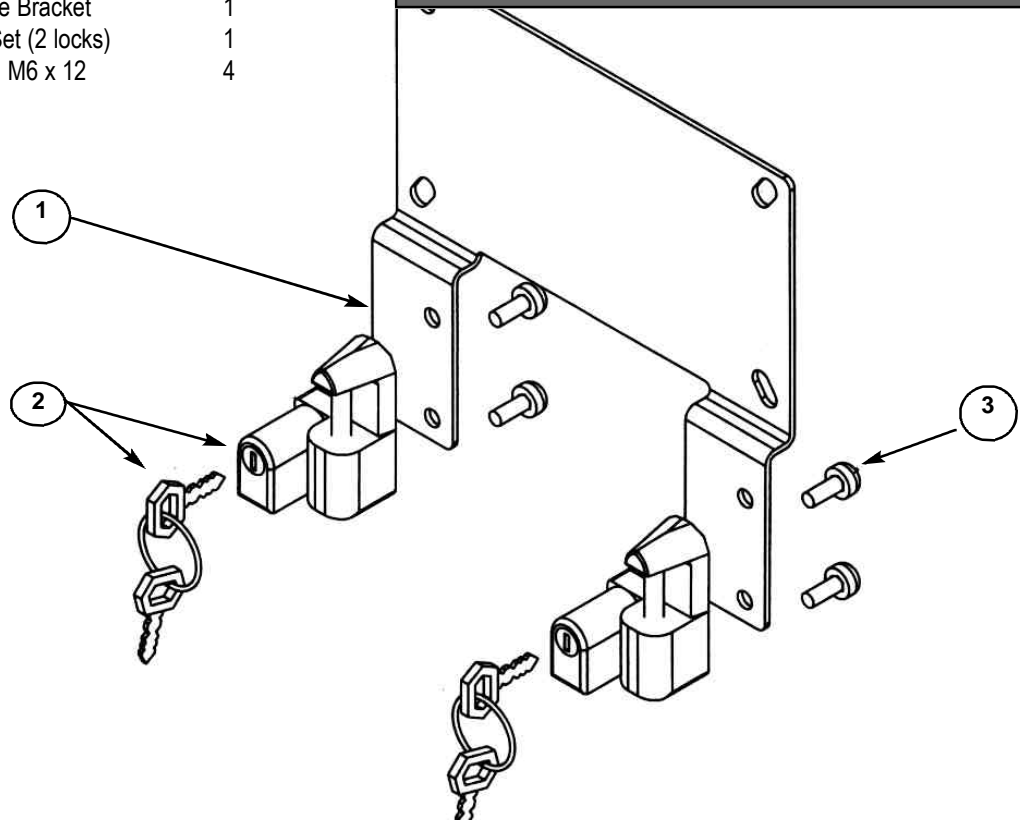

PREPARATION

1. Park motorcycle on flat level ground.
2. Remove license plate.

INSTALLATION

Note: A drop of Loctite® threadlocker can be applied to each M6 x 12 screw before installing into lock.

1. Install locks to lock plate. From the back, insert a M6 x12 screw through the lock plate and into the lock. Repeat procedure at other locations. Firmly tighten screws. Figure 1.
2. Install lock plate to motorcycle. Place license plate over top of lock plate. Install to motorcycle with original screws.

CAUTION

This helmet lock is manufactured as convenience to the user and a deterrent to helmet theft. It is not intended as a security device.

MAINTENANCE

The high quality chrome finish of your ZTechnik Helmet Lock can be maintained with any quality chrome cleaner and /or polish.